

Symmetry Vertical Platform Lift

Model Hybrid

Continuous Pressure Lift

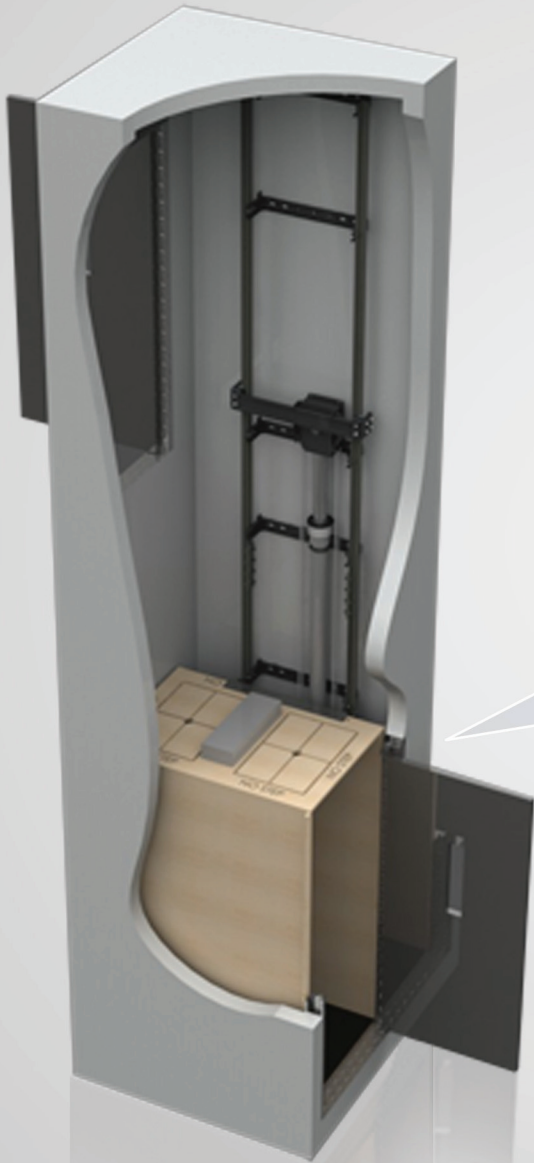

 **symmetry**
More space for living.



www.symmetryelevator.com

Convenient access to all levels

Whether it's commercial or residential use, Symmetry vertical platform lifts eliminate the barrier that stairs can cause for people with limited mobility. A cost-effective solution, platform lifts create convenient access without compromising architectural character.

The Symmetry Hybrid looks and feels like an elevator, but operates like a lift. Available in many different sizes and configurations, features include a full height cab, non-load bearing ceiling and a wide variety of optional features and finishes. Customize the doors & cab to match the style and decor of your commercial facility or home.

Standard Features

- Roped Hydraulic Drive System with Submersed Power Unit
- 750-lb. capacity
- 30 Feet per Minute
- Lifting Height: up to 168 inches
- Pit Depth: 6" Minimum (8" Preferred)
- Top Landing Ceiling Overhead: 96" minimum
- Self Diagnostic System with Digital Display
- Automatic Cab Lighting
- Emergency Lights
- Constant Pressure, Elevator-Style Control Switch installed in cab
- Constant Pressure, Elevator-Style Stations provided at each landing

Optional Features

- Wide Variety of Custom Fixture & Interior Designs
- Remote Mounted Controller and Hydraulic Pump
- ADA Phone
- Key-Switch to lock platform and landing controls

Platform Sizes

- 36" W x 48" D
- 36" W x 54" D
- 36" W x 60" D
- 42" W x 60" D

Platform Enter/Exit Configurations

- Straight Through Enter/Exit
- Same Side Enter/Exit
- 90° enter/exit

Safety Features

- Alarm and Emergency Stop Switch
- Grab Rail
- Landing interlocks to keep doors closed when lift is on another floor
- Un-interruptible Power Supply for car lowering in the event of power failure
- Manual Lowering
- Rupture Valve

Door Options

- Power Door Operators available
- Fire-Rated Flush Closing Steel Doors
- Non Fire-Rated Flush Closing Oak Doors
- Other wood door choices available, by request

The information contained in this document is intended for the general planning & design phase only and should not be used for construction purposes. Contact your Symmetry representative for job specific shop drawings and construction requirements.

Platform Enter/Exit Configurations & Sizes

Clear Platform Width (A)	Clear Platform Length (B)	Finished Hoistway Width (C)	Finished Hoistway Length (D)
Straight Through Configuration			
36"	48"	51 1/2"	49 1/2"
36"	54"	51 1/2"	55 1/2"
36"	60"	51 1/2"	61 1/2"
42"	60"	57 1/2"	61 1/2"
Enter Exit Same Side Configuration			
36"	48"	51 1/2"	53 1/2"
36"	54"	51 1/2"	59 1/2"
36"	60"	51 1/2"	65 1/2"
42"	60"	57 1/2"	65 1/2"
90° Exit Configuration			
36"*	60"	53 1/2"	65 1/2"
42"	60"	59 1/2"	65 1/2"

*In a 90° Exit Configuration 36"x 60" is Only Available for Existing Construction.

Note: A small machine room area may be required, depending on local jurisdiction requirements. Contact Symmetry Dealer for details.

Straight Through Configuration

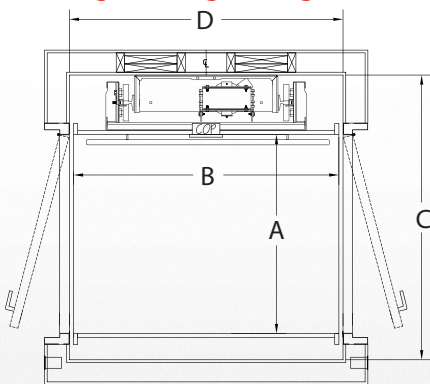

Enter Exit Same Side Configuration

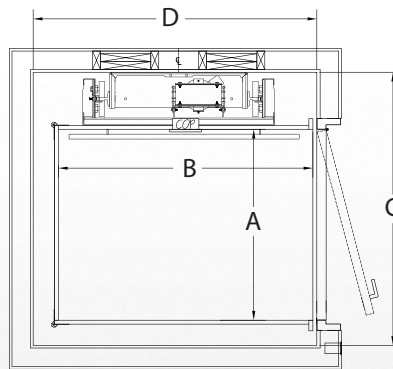

90° Exit Configuration

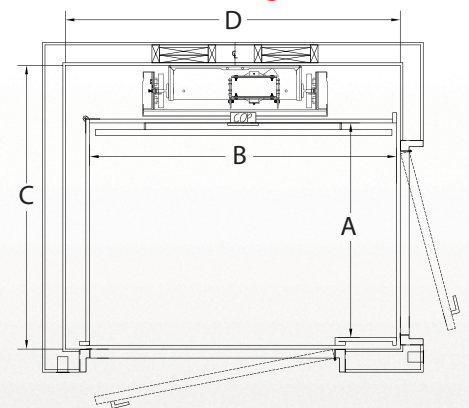

symmetry
More space for living.

877.375.1428 | symmetryelevator.com
301.05/11